

HolyToledo West Hobie 33 MOD 77520

Spinnaker	GPH: 0.862 / 614.2	IR#: 0.866 / 619.2	PHRF BM: 83.0
Non-Spin	GPH: 0.817 / 648.4	IR#: 0.842 / 637.1	PHRF BM: 100.9

Class:	Hobie 33 MOD
Configuration:	
Sail Number:	77520
Year Built:	1983
Builder:	Hobie Cat
Owner(s):	Forderer, Timothy
Certificate #:	EZ11917-2
Valid Year:	2024
Type:	Mid Seas Change
Issue Date:	2024-05-22
Exp.Date:	2024-12-31
Offsets_file:	DARKSTAR.OFF
Cert Group:	ORR-Ez SOCAL
Comment:	
Rig Type:	Sloop
Forestay:	Fractional
Keel Type:	Fin with Bulb
Prop Type:	None
LOA:	32.59 ft
LWL:	30.50 ft
Rated Length:	30.50 ft
Beam Max:	8.04 ft
Draft:	5.30 ft
Disp Empty:	4006 lbs
Disp Sailing:	5472 lbs
Crew:	1154 lbs
Water Ballast:	0 lbs
Wetted Area:	186.2 ft ²
LPS:	130.0 °
RM20:	334.4 ft-lbs
Stab Index:	128 °

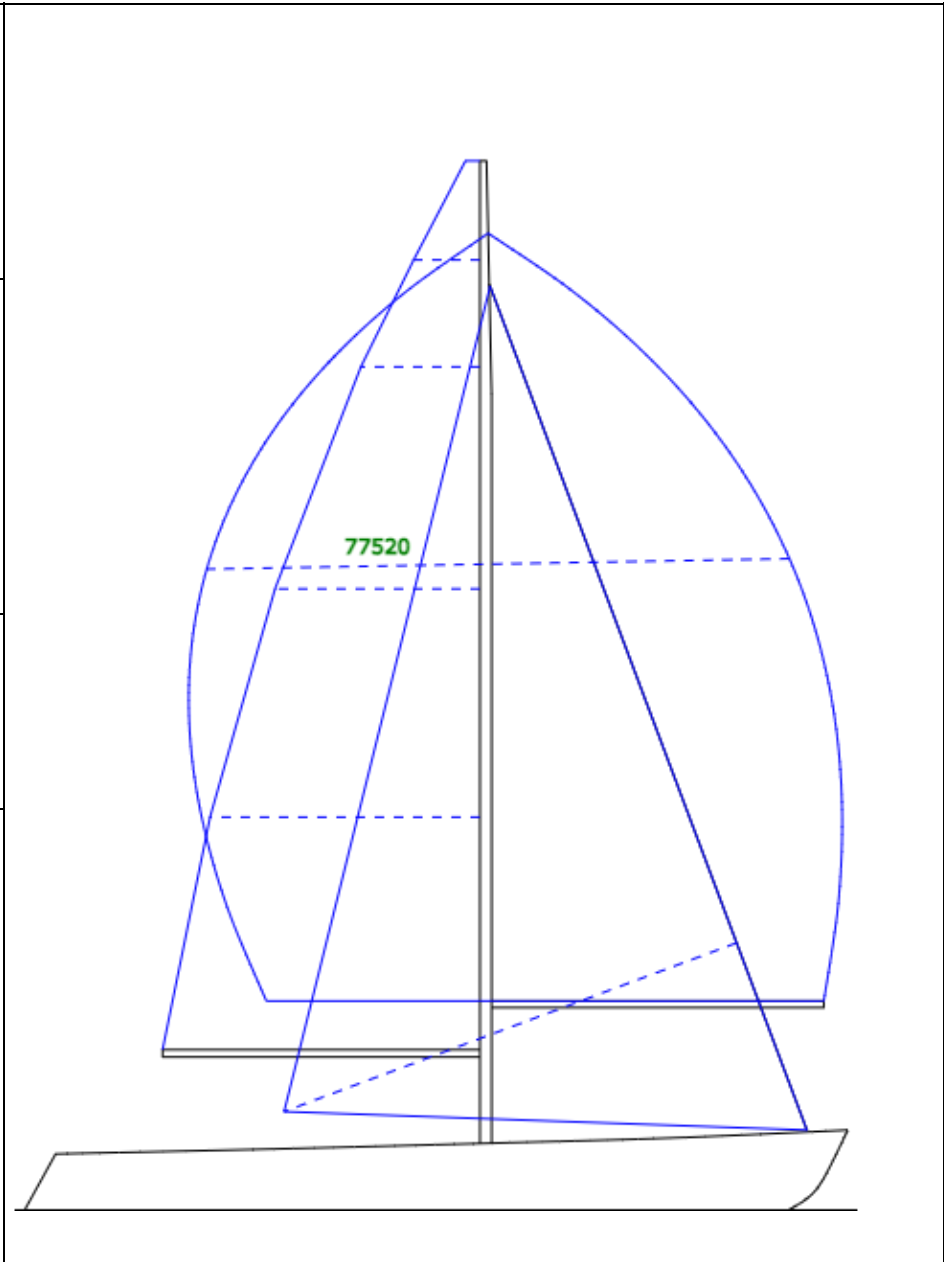

Spinnaker:	Symmetrical flown with spinnaker pole
Genoa/Jib Leech:	No Roach - Leech is straight
Large Roach Headsail:	No
Jib Furler:	No
Main Roller Furling:	No

Rig Dimensions	Mainsail Meas.	Jib/Genoa Meas.	Symmetric Spin. Meas.
IG: 33.83 ft	HB: 0.57 ft	LP: 19.02 ft	SL: 36.51 ft
ISP: 35.83 ft	MGT: 2.61 ft	LPG %: 152.2 %	SMW: 22.95 ft
J: 12.42 ft	MGU: 4.69 ft	J Luff: 35.49 ft	SF: 21.96 ft
P: 35.00 ft	MGM: 8.07 ft	J Leech: 33.53 ft	Area: 692.2 ft ²
E: 12.50 ft	MGL: 10.63 ft	Area: 337.4 ft ²	
SPL: 13.08 ft	Area: 267.4 ft ²		

Spinnaker

Polar Time Allowances

True Wind Speed	4 kts	6 kts	8 kts	10 kts	12 kts	16 kts	20 kts	24 kts
Opt Beat Angle	47.1	46.2	45.2	42.3	40.3	38.3	37.9	38.2
Beat VMG	1,535.12	1,096.59	885.78	794.44	748.11	707.14	693.07	690.33
52°	954.91	691.12	566.89	526.89	506.71	487.33	478.32	475.06
60°	848.84	629.05	531.06	499.43	481.74	463.26	453.91	449.89
75°	757.24	573.60	498.06	467.37	449.62	426.97	410.96	400.48
90°	756.67	566.08	483.66	449.51	425.63	392.14	370.01	354.30
110°	752.27	562.06	479.42	433.88	404.88	359.32	327.12	307.01
120°	790.43	586.98	496.83	449.93	411.50	348.69	311.33	286.67
135°	1,049.86	726.31	567.21	503.69	461.54	387.60	309.92	262.26
150°	1,285.81	889.55	693.31	585.78	516.94	436.95	368.86	299.63
165°	1,434.13	992.16	773.29	653.35	570.41	473.11	407.69	334.20
Run VMG	1,484.72	1,027.16	800.57	676.40	590.53	489.42	422.07	345.99
Opt Run Angle	131.1	133.5	136.5	146.8	158.0	167.9	164.8	143.2

Benchmark Ratings

	TOT (Spin)	TOD (Spin)
GPH	0.862	614.2
IR#	0.866	619.2

Performance Metrics

SA/D Dnwind:	49.450
SA/D Average:	40.31
SA/D Upwind:	31.170
D/Length:	86.1
Ave Perf Screen:	46.800
DnWind Perf	57.4
Screen:	

PCS Ratings

	4 kts	6 kts	8 kts	10 kts	12 kts	16 kts	20 kts	24 kts
RANDOM LEG	1,202.6	854.7	686.4	596.9	542.9	483.4	447.7	421.3
W50/L50	1,532.7	1,080.5	859.7	745.7	678.0	604.6	562.4	522.6
W60/L40	1,538.4	1,088.1	869.0	758.0	694.0	626.6	589.9	557.5
MOSTLY WW	1,592.1	1,132.4	910.2	794.6	728.7	667.4	642.2	629.9
MOSTLY LW	1,316.2	921.8	728.2	619.0	548.5	462.5	405.7	356.4
MOSTLY REACH	1,088.9	778.2	628.9	550.7	503.7	450.1	415.8	392.4

Non-Spinnaker

Polar Time Allowances

True Wind Speed	4 kts	6 kts	8 kts	10 kts	12 kts	16 kts	20 kts	24 kts
Opt Beat Angle	47.1	46.2	45.2	42.3	40.3	38.3	37.9	38.2
Beat VMG	1,535.12	1,096.59	885.78	794.44	748.11	707.14	693.07	690.33
52°	954.91	691.12	566.89	526.89	506.71	487.33	478.32	475.06
60°	848.84	629.05	531.06	499.43	481.74	463.26	453.91	449.89
75°	757.24	573.60	498.06	467.37	449.62	428.67	417.02	409.78
90°	747.15	566.08	491.67	451.74	429.75	403.17	386.22	372.91
110°	836.06	619.77	523.42	479.00	443.93	384.48	354.02	333.51
120°	979.33	700.95	567.48	510.86	472.93	409.98	348.30	321.90
135°	1,348.92	919.68	705.77	590.29	526.05	451.18	389.99	328.86
150°	1,672.09	1,106.43	823.69	674.13	576.35	478.46	415.23	354.28
165°	1,745.88	1,166.67	877.09	711.21	603.69	488.90	421.06	359.73
Run VMG	1,771.83	1,183.35	889.11	720.35	611.03	494.23	425.93	364.08
Opt Run Angle	171.9	172.0	172.1	172.1	172.0	172.5	171.9	170.9

Benchmark Ratings

	TOT (Non-Spin)	TOD (Non-Spin)
GPH	0.817	648.4
IR#	0.842	637.1

Performance Metrics

SA/D:	31.17
D/Length:	86.1
Perf Screen:	36.2

PCS Ratings

	4 kts	6 kts	8 kts	10 kts	12 kts	16 kts	20 kts	24 kts
RANDOM LEG	1,301.1	917.3	729.9	628.8	567.9	502.7	466.9	441.9
W50/L50	1,669.3	1,156.8	903.3	768.4	689.0	607.2	564.8	532.1
W60/L40	1,647.2	1,149.2	903.9	776.2	702.8	628.7	591.8	565.1
MOSTLY WW	1,614.1	1,145.8	918.9	800.0	732.3	669.4	644.7	634.1
MOSTLY LW	1,497.1	1,031.8	800.9	670.7	587.4	488.4	427.5	385.4
MOSTLY REACH	1,184.8	840.5	673.5	584.2	530.6	472.3	438.6	413.2

HolyToledo West Hobie 33 MOD 77520

Spinnaker

Standard 5 Winds

	TOT (Spin)					TOD (Spin)				
	V.Light <5	Light 5-7	Lt/Med 7-9	Medium 9-15	Heavy >15	V.Light <5	Light 5-7	Lt/Med 7-9	Medium 9-15	Heavy >15
RANDOM LEG	0.433	0.569	0.730	0.890	1.154	1,202.6	914.5	712.7	584.8	450.8
W50/L50	0.414	0.548	0.709	0.868	1.127	1,532.7	1,157.6	895.3	731.2	563.2
W60/L40	0.421	0.556	0.716	0.869	1.095	1,538.4	1,165.1	905.0	745.3	591.4
MOSTLY WW	0.432	0.567	0.727	0.878	1.063	1,592.1	1,211.6	945.7	782.9	646.5
MOSTLY LW	0.402	0.535	0.699	0.881	1.295	1,316.2	988.7	756.3	600.3	408.2
MOSTLY REACH	0.446	0.584	0.744	0.899	1.158	1,088.9	832.0	652.6	540.0	419.4

Standard Single Wind

	TOT (Spin) Single	TOD (Spin) Single
RANDOM LEG	0.864	602.0
W50/L50	0.840	755.2
W60/L40	0.840	770.9
MOSTLY WW	0.846	812.6
MOSTLY LW	0.861	614.3
MOSTLY REACH	0.875	554.6

Legacy 4 Winds

	TOT (Spin)				TOD (Spin)			
	V.Light	Light	Medium	Heavy	V.Light	Light	Medium	Heavy
RANDOM LEG	0.400	0.642	0.876	1.068	1,202.6	748.2	549.0	450.0
W50/L50	0.384	0.625	0.858	1.045	1,532.7	941.6	685.8	563.0
W60/L40	0.390	0.632	0.856	1.016	1,538.4	950.8	701.6	591.0
MOSTLY WW	0.395	0.634	0.853	0.975	1,592.1	992.4	737.5	645.4
MOSTLY LW	0.369	0.609	0.875	1.193	1,316.2	797.7	555.4	407.5
MOSTLY REACH	0.414	0.659	0.886	1.076	1,088.9	684.0	508.7	418.5

Non-Spinnaker

Standard 5 Winds

	TOT (Non-Spin)					TOD (Non-Spin)				
	V.Light <5	Light 5-7	Lt/Med 7-9	Medium 9-15	Heavy >15	V.Light <5	Light 5-7	Lt/Med 7-9	Medium 9-15	Heavy >15
RANDOM LEG	0.400	0.530	0.686	0.845	1.106	1,301.1	982.8	758.7	615.5	470.5
W50/L50	0.380	0.511	0.673	0.844	1.117	1,669.3	1,243.2	942.9	752.2	568.0
W60/L40	0.393	0.525	0.687	0.850	1.088	1,647.2	1,233.5	943.1	762.2	595.2
MOSTLY WW	0.426	0.560	0.720	0.872	1.058	1,614.1	1,226.3	954.9	788.0	649.4
MOSTLY LW	0.353	0.476	0.634	0.815	1.219	1,497.1	1,110.0	834.5	649.2	433.8
MOSTLY REACH	0.410	0.540	0.694	0.848	1.100	1,184.8	899.6	699.4	572.4	441.4

Standard Single Wind

	TOT (Non-Spin) Single	TOD (Non-Spin) Single
RANDOM LEG	0.819	635.6
W50/L50	0.812	781.6
W60/L40	0.818	792.1
MOSTLY WW	0.839	818.5
MOSTLY LW	0.792	667.8
MOSTLY REACH	0.823	589.9

Legacy 4 Winds

	TOT (Non-Spin)				TOD (Non-Spin)			
	V.Light	Light	Medium	Heavy	V.Light	Light	Medium	Heavy
RANDOM LEG	0.369	0.602	0.836	1.024	1,301.1	798.3	575.0	469.6
W50/L50	0.352	0.590	0.842	1.037	1,669.3	996.4	698.6	567.2
W60/L40	0.365	0.604	0.844	1.010	1,647.2	994.6	711.9	594.4
MOSTLY WW	0.390	0.628	0.849	0.971	1,614.1	1,002.6	741.4	648.2
MOSTLY LW	0.325	0.550	0.816	1.125	1,497.1	883.8	595.9	432.2
MOSTLY REACH	0.380	0.613	0.839	1.022	1,184.8	734.7	536.7	440.7

Spinnaker

PHRF Benchmark

83.0

Aligned Ratings are based on the Farr 40 MH as Scratch Boat.

PHRF Single Wind

RANDOM LEG	81.6
W50/L50	120.5
W60/L40	123.1
MOSTLY WW	125.5
MOSTLY LW	85.5
MOSTLY REACH	69.1

PHRF 5 Winds

	V.Light <5	Light 5-7	Lt/Med 7-9	Medium 9-15	Heavy >15
RANDOM LEG	213.8	152.3	108.0	77.2	47.8
W50/L50	325.2	229.0	158.9	111.6	75.3
W60/L40	318.9	226.6	159.5	114.4	81.3
MOSTLY WW	285.5	209.6	155.1	118.9	92.2
MOSTLY LW	254.4	177.7	121.8	81.4	37.2
MOSTLY REACH	182.1	130.0	92.1	65.9	37.8

Non-Spinnaker

PHRF Benchmark

100.9

Aligned Ratings are based on the Farr 40 MH as Scratch Boat.

PHRF Single Wind

RANDOM LEG	115.2
W50/L50	146.9
W60/L40	144.3
MOSTLY WW	131.4
MOSTLY LW	139.0
MOSTLY REACH	104.4

PHRF 5 Winds

	V.Light <5	Light 5-7	Lt/Med 7-9	Medium 9-15	Heavy >15
RANDOM LEG	312.3	220.6	154.0	107.9	67.5
W50/L50	461.8	314.6	206.5	132.6	80.1
W60/L40	427.7	295.0	197.6	131.3	85.1
MOSTLY WW	307.5	224.3	164.3	124.0	95.1
MOSTLY LW	435.3	299.0	200.0	130.3	62.8
MOSTLY REACH	278.0	197.6	138.9	98.3	59.8